

# 4405-E26

120V

Catalog #:		Type
Project:		Date
Prepared by:		

## Outdoor Wall Lantern, E26 A19 LED Lamp Included

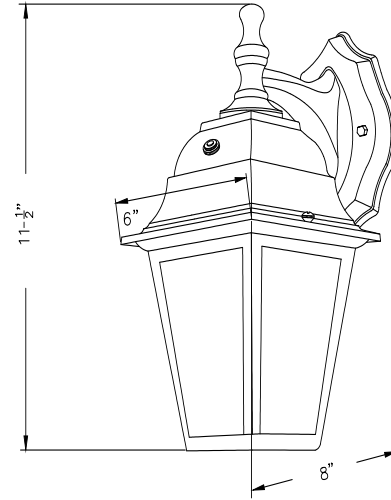

### DESCRIPTION

The 4405-E26 LED Outdoor Wall Lantern is the ideal choice for outdoor applications for building-mounted doorway and pathway illumination. The E26 A19 LED included lamps allows for improved life and energy savings.

### DESIGN FEATURES

#### Construction

- Durable steel construction with clear bubble glass lens
- Daylight photocell included

#### Electrical

- 120V-60Hz
- 50,000 hour projected life
- 3000K | 80 CRI
- 1 x 9W E26 A19 LED lamp included
- Operating temperature: -4°F (-20°C) to 104°F (40°C)

#### Dimension

- 11-1/2" H x 6" W x 8" D

#### Certifications

- CEC JA8 Listed \*
- cETLus Listed for wet location
- LED Lamp: 5 Year Limited Warranty
- Non-Electrical: 1 Year Limited Warranty

### ORDERING GUIDE

Example: 4405BK-E26

Model #	Finish	Lamp
4405	BK	-E26
4405	BK : Black	-E26

\* Included A19 LED lamp listed on CEC JA8 website as L9-A19DG-9W-30