

# 4908

120V

Catalog #:		Type
Project:		Date
Prepared by:		

## 1 - 4 A19 LED Vanity Light

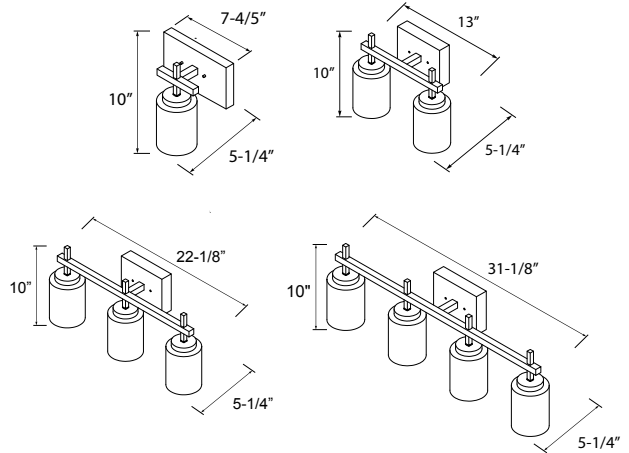

### DESCRIPTION

See yourself in the best light with the 4908 Series A19 LED Vanity Light that can be mounted in direct or indirect positions. This stylish vanity is damp location rated and is energy efficient. Choose from a 1-light to 4-light configurations for any damp location application.

### DESIGN FEATURES

#### Construction

- Heavy duty, stainless steel construction
- Opal glass shade

#### Electrical

- 120V-60Hz
- Dimmable TRIAC or ELV, 10-100%
- 9W E26 A19 LED lamps included
- 50,000 hour projected life
- 3000K | 80 CRI | 800 lms per lamp (source)

#### Installation

- Quick and easy wall mount installation
- Fixture can be mounted with glass shades facing up or down
- Back plate is 5" x 6" and will accommodate most J-Boxes

#### Certifications

- cETLus listed for damp locations
- Energy Star listed (BN finish only)
- 1 Year limited warranty

### ORDERING GUIDE

Example: 4908BN-3

Model #	Finish	# of Lights
4908		
4908	BN : Brushed Nickel MBK : Matte Black*	-1 : 1 lights -2 : 2 lights -3 : 3 lights -4 : 4 lights

\* MBK Finish available in -2, -3, and -4 configuration

TEL: 800.937.6925 | Fax: 800.207.9509 | [www.rplighting.com](http://www.rplighting.com)

Specifications and dimensions subject to change without notice.

10/4/24 R3



4908 - 1-4 A19 LED Vanity Light