

# 4116-1

120V-277V Universal Voltage

Catalog #:		Type
Project:		Date
Prepared by:		

## 4' Stairwell - NON-Dimmable

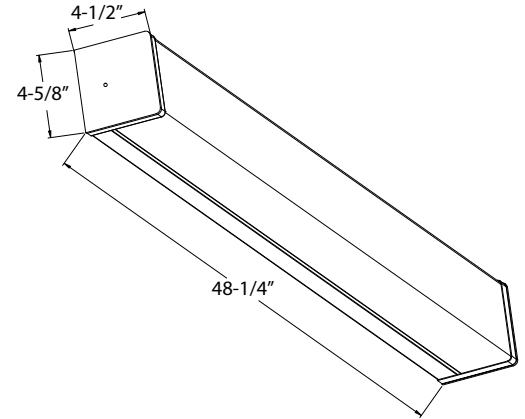

### DESCRIPTION

Safety, reliability, and efficiency are just a few things that come to mind when thinking stairwell lighting. Our LED stairwell lights deliver just that in a simple and practical design. You can increase your energy savings with the optional Motion sensor by only lighting the stairwell when occupied. With the available Emergency Battery Pack option, this increases your available applications for this useful fixture.

### DESIGN FEATURES

#### Construction

- Heavy-duty steel housing
- Frosted Acrylic Lens
- White Finish

#### Electrical

- 120V-277V Universal Voltage
- Non-dimmable
- 40W | 5110 lms | 127lms/W (delivered)
- 50,000 hours projected life
- 4000K | 80 CRI
- Beam angle - 118 (V), 140 (H)

#### Emergency (EM) Option

- RP Lighting 4782-1EM emergency battery back up factory installed (see separate 4782-1EM spec sheet for further details)
- Emergency Output = 9W
- Emergency lumen output - 9W x fixture L/W  
(127Lms x 9W) = 1,143 nominal lumens

#### Installation

- Ceiling or wall mount

#### Dimensions

- 48-1/4" L x 4-1/2" W x 4-5/8" H

#### Available options

- Motion Sensor: 4760MS
- 4116-1WH-MS
- Emergency Battery Backup 4116-1WH-EM
- Both 4116-1WH-MS-EM

#### Certifications

- cCSAus Certified
- DLC 5.1 listed
- LED Lamps: 5 Year Limited Warranty
- Other components: 1 Year Limited Warranty
- Listed for Damp Location

### ORDERING GUIDE

4116-1WH-MS-EM

Model #	Finish	Sensor Option
4116-1	WH	
4116-1	WH : White	-MS : Microwave motion/occupancy/daylight sensor -EM : Emergency Battery Backup -MS-EM : Both

\* For 2' Stairwell see 4115-1 or 4115DM-1

\* For 4' Dimming Stairwell see 4116DM-1



LED Light Source Other Components

TEL: 800.937.6925 | Fax: 800.207.9509 | [www.rplighting.com](http://www.rplighting.com)

Specifications and dimensions subject to change without notice.

2/19/24



RP LIGHTING · FANS